

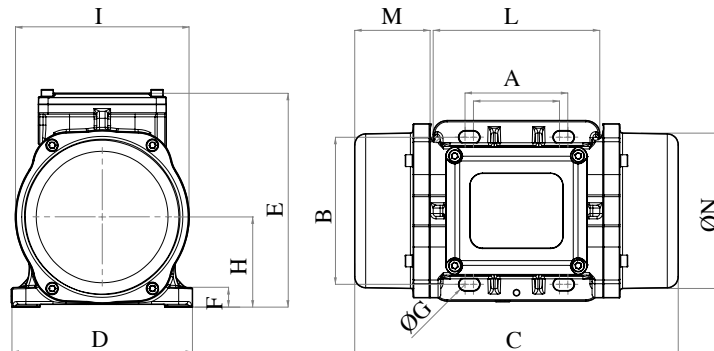

MVE 200/3E-20A0-M (EE20020020A0MA0000)

1 PH - 2 poles - 3000 RPM - 230 V (1PH) - 50 Hz

Working moment (Kg*cm)	Unbalance (Kg*cm)	Centrifugal force (Kg)	Nominal voltage (V)	Input power (kW)	Current (A)	Power Factor	Ia/In
3,72	1,86	187	230 (1PH)	0,18	1,14	0,69	3,5



OVERALL DIMENSIONS (mm)													
Weight (Kg)	A	B	G	Holes number	C	D	E	F	H	I	L	M	N
7	62-74	106	106	4	233	130	154	15	65	125	120	54	112

TECHNICAL FEATURES						
Type of grease	Greased for life	Screw	Washer	Clamping torque (Nm)	Cable type	Cable gland
/	Yes	M8	8,4 x 16 mm	23	4G2.5 80°C	M20 80°C

BEARINGS				
Bearing model	Type	Life 100%	Life 80%	Life 50%
6302 2Z		5522	10785	44176

CERTIFICATION	
ATEX II2 D Ex tb IIIC T135°C Db IP66 IECEx Ex tb IIIC T135°C Db IP66 CLASS II DIV.2 GROUP F,G T4 Ex tb IIIC Tx Db IP66 CONFORM TO UL1004-3, UL1004-1, UL 60079-0, UL60079-31 CERT. CSA C22.2 No.100, CSA C22.2 No.77, CSA C22.2N.60079-0, CSA C22.2N.60079-31 T.Amb -20/+40°C	