

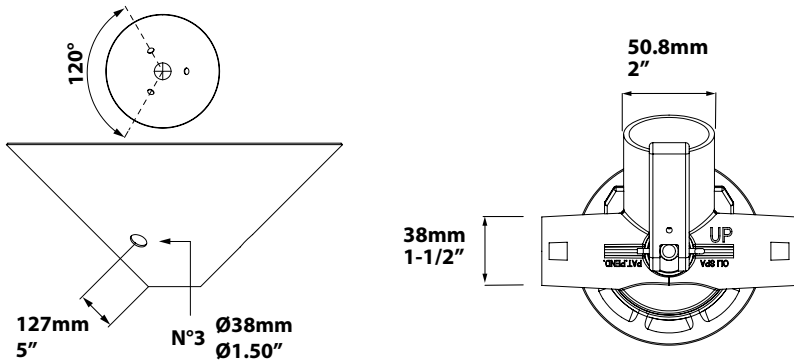

VBT - Tank truck aerators

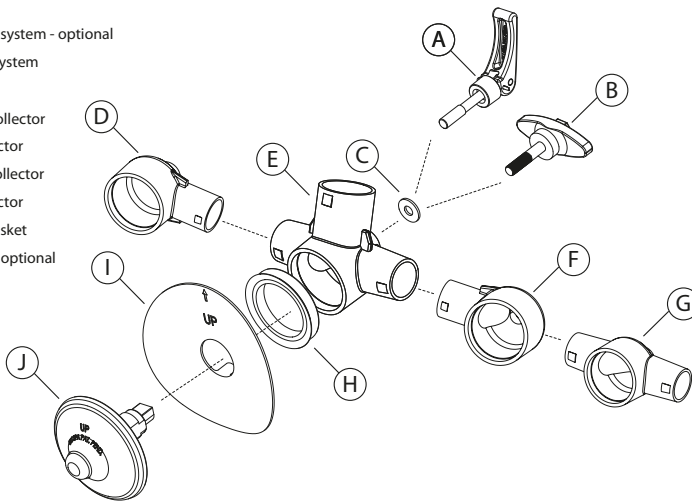

- (A) Cam lever lock system - optional
- (B) T-handle lock system
- (C) Gasket
- (D) RH 1-Way air collector
- (E) 3-Way air collector
- (F) LH 1-Way air collector
- (G) 2-Way air collector
- (H) Air collector gasket
- (I) Hopper saver - optional
- (J) Membrane



VBT SERIES

APPLICATION	Dry bulk tank trailer, rail tanker
POWDER	Dry, fine, granular
PROBLEM SOLVING	Bridging and rat-holing

FEATURES

DUTY CYCLE	Continuous [suitable to be used with blower]
WORKING PRESSURE	From 0.7 bar to 2 bar (from 10 psi to 29 psi)
PNEUMATIC CIRCUIT	Suitable standard pneumatic bulk trailer, works with all standard designs
WORKING TEMPERATURE	From -40 °C to 170 °C (from -40 °F to 340 °F)
TECHNOLOGY	Vibro-aeration
MATERIAL	Blue silicone membrane: metal detectable, comply with FDA 177.2600 Stem - Black polyarylamide glass-fiber reinforced comply with 10/2011/EC - FDA - UL94 Manifold - Black polyarylamide glass-fiber reinforced comply with 10/2011/EC - FDA - UL94 Manifold - Transparent material comply with ISO 10993 - FDA 21 CFR 177.1655 - NSF 51 - UL94 Lever and T-handle - Black polyarylamide glass-fiber reinforced / Stainless steel thread shaft Silicone gasket

OPTIONS

CAM LEVER	Shaft material: AISI304
HOPPER SAVER PLATE	Stainless steel

This information is furnished without warranty, representation, inducement or license of any kind. It is accurate to the best OLI knowledge or is obtained from sources believed to be accurate. OLI therefore assumes no legal responsibility.